



REMORQUES

SA A.I.N.

www.remorques-rocca.com

Moyeu étanche

garantie 2 ans

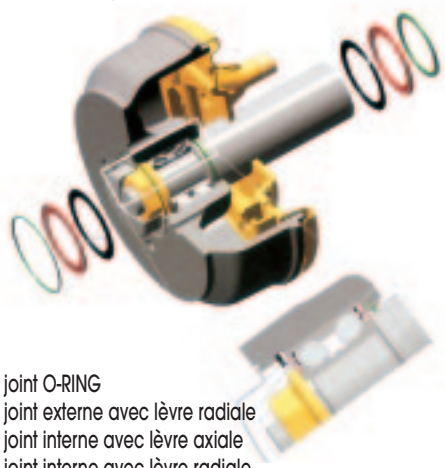

- 1- joint O-RING
- 2- joint externe avec lèvres radiale
- 3- joint interne avec lèvres axiale
- 4- joint interne avec lèvres radiale
- 5- joint interne avec lèvres radiale
- 6- joint interne avec lèvres axiale
- 7- joint externe avec lèvres radiale
- 8- bague de joint en acier inoxydable

LA PERFORMANCE ALL INNOVATION

PORTE TREUIL

Le support treuil s'adapte à toutes les formes de carène, réglage ultra rapide.

Le treuil à sangle facilite le guidage et évite les inconvénients du câble.

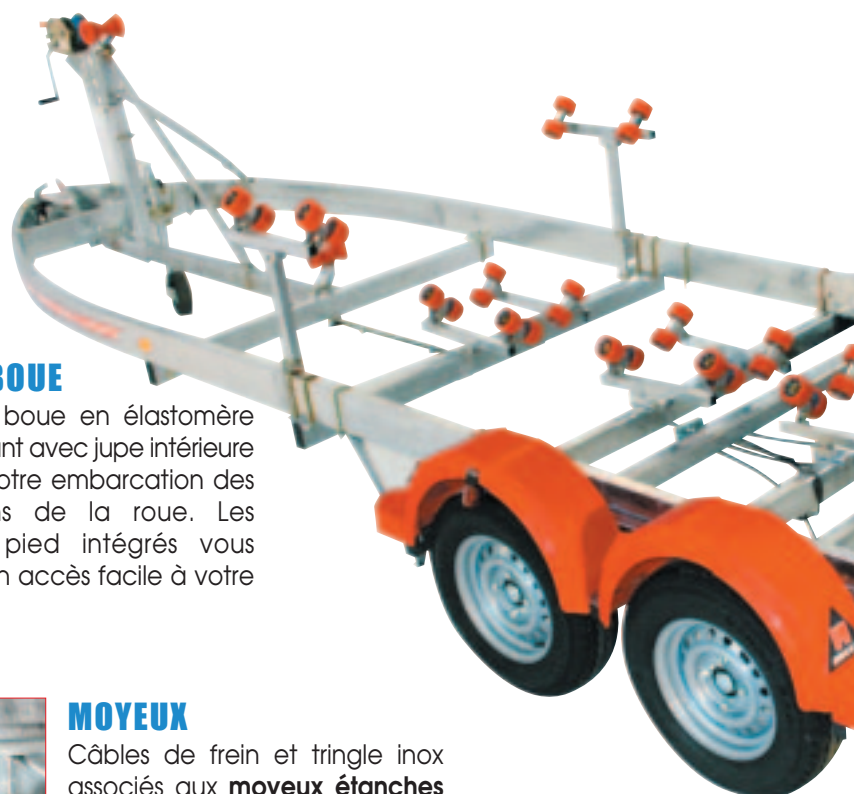

GARDE BOUE

Le garde boue en élastomère ultra résistant avec jupe intérieure protège votre embarcation des projections de la roue. Les marches pied intégrés vous assurent un accès facile à votre bateau.



MOYEURS

Câbles de frein et tringle inox associés aux **moyeux étanches** garantissent sécurité et longévité de votre remorque.

Seul constructeur français à proposer le frein de parking à rattrapage automatique.

RAMPE DE FEUX

Légère et facilement démontable

CHÂSSIS

Toutes nos remorques sont équipées d'un double châssis et de longerons en V cintrés à froid assurant une stabilité et une résistance supérieure à toute autre fabrication.



Les caractéristiques indiquées sont susceptibles d'être modifiées suivant le type de votre bateau. Tous nos renforts peuvent être modifiés sans préavis. Photos non contractuelles.

GARANTIE - Nous garantissons nos travaux et fournitures exempts de tous vices cachés, ou apparents, pendant deux ans. Nous nous engageons à remplacer ou à remettre en état toute pièce reconnue par nous défectueuse. Mais nous ne sommes pas responsables de la casse ou de l'usure normale. Pour toutes les pièces non fabriquées par nous, la garantie se limite aux conditions de nos fournisseurs.

Photos non contractuelles

IEE A LA ROBUSTESSE ET FIABILITE



ROULEAUX

Les rouleaux en santoprène non tachant SOFT ont été réalisés afin d'améliorer le roulage.

Le noyau en polypropylène est quasiment indestructible.

QUADRUPLE ROULEAUX

Installés au centre de la remorque ils assurent une grande efficacité lors des mises à l'eau, orientables en tous sens ils s'adaptent à toutes les carènes.

Ils assurent le guidage parfait lors de la sortie d'eau de la coque.

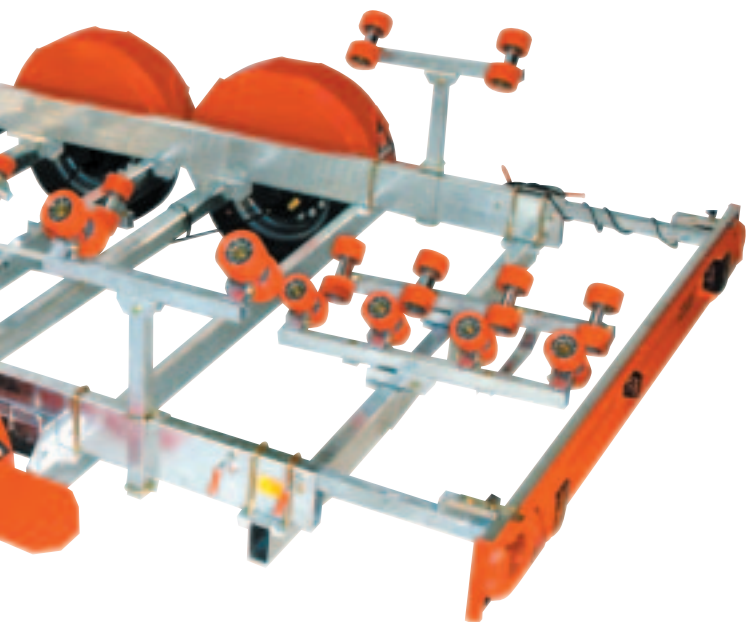

ENTRETIEN

Flasque du tambour à embout de rinçage, facilite le nettoyage du système de freinage.

Sécurité optimale.

Les renseignements sont donnés à titre indicatif et sont susceptibles

de varier sans préavis. Garantie de deux ans à dater de la livraison au premier acheteur. Nous nous

ne sommes pas tenus au remplacement de la remorque dans sa tota-

SOMMAIRE



REMORQUES

BARQUE

PAGE 1

DÉRIVEUR LÉGER

PAGE 2

CATAMARAN DE SPORT

PAGE 4

PLANCHE À VOILE, CANOË

PAGE 5

DÉRIVEUR

PAGE 6

VOILIER, DÉRIVEUR ET QUILLARD

PAGE 7

JET

PAGE 8

PNEUMATIQUE

PAGE 9

SEMI-RIGIDE

PAGE 10

BATEAU À MOTEUR

PAGES 11 & 12

BATEAU PÊCHE, PROMENADE À QUILLE

PAGE 13

CHARIOTS

DÉRIVEUR

PAGE 3

MISE À L'EAU

PAGE 14

REMORQUES SPÉCIALES

PAGE 15 et 16



Spécial Barque

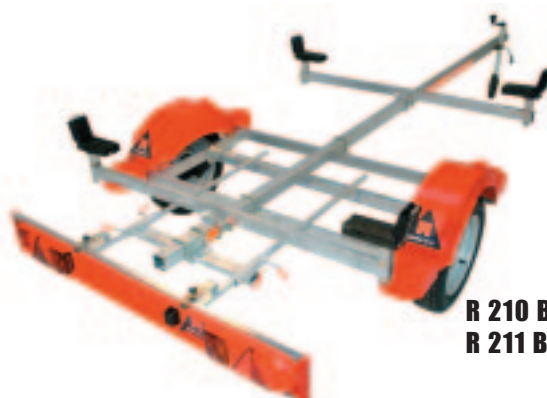

**R 210 B
R 211 B**

**R 270 AP
R 271 AP**

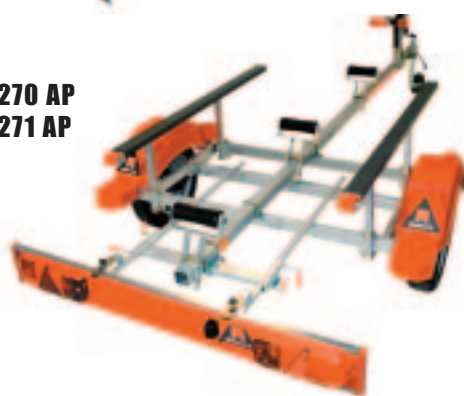

**R 330 AP
R 331 AP**

	Variable suivant version Charge utile	P.T.C.	Longueur bateau	Suivant version Longueur remorque	Suivant version Largeur remorque	Nombre rouleaux	Roues
SBARQUE	220	300	4.50	4.00/4.50	1.69	2 rampes	400 x 480 x 8
R 210 B	250	320	3.50	4.00	1.69	4 patins	450 / 10
R 211 B	250	320	3.50	4.00	1.69	4 patins	145 / 70 x 13
R 270 AP	300	350	3.70	4.00	1.69	2 rampes + 3 rlx	450 / 10
R 271 AP	300	350	3.70	4.00	1.69	2 rampes + 3 rlx	145 / 70 x 13
R 330 AP	350	470	4.50	4.70	1.89	2 rampes + 3 rlx	450 / 10
R 331 AP	350	470	4.50	4.70	1.89	2 rampes + 3 rlx	145 / 70 x 13

Photos non contractuelles



R 210 D
R 211 D



R 270 D
R 271 D

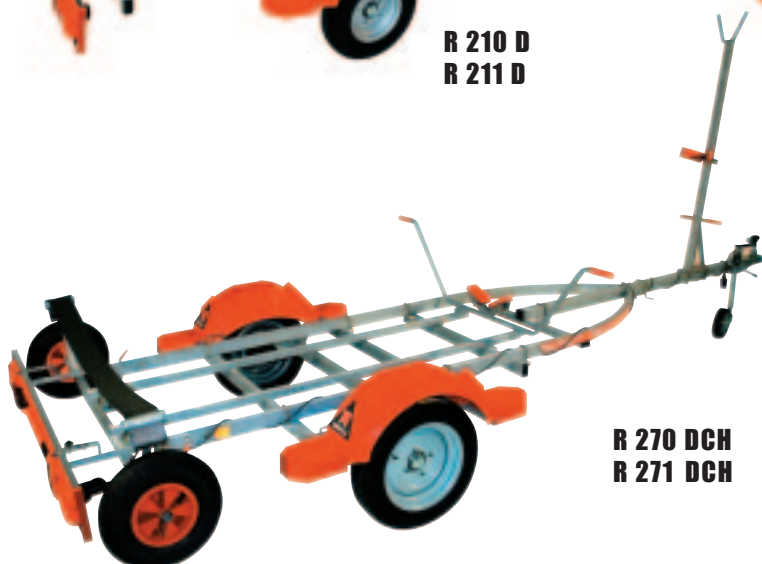

R 270 DCH
R 271 DCH

	Variable suivant version Charge utile	P.T.C.	Longueur bateau	Suivant version Longueur remorque	Suivant version Largeur remorque	Nombre rouleaux	Roues
R 210 D	220	320	3.90	4.00	1.69	4 patins + 1 sgle	450 / 10
R 211 D	220	320	3.90	4.00	1.69	4 patins + 1 sgle	145 / 70 x 13
R 270 D	270	400	4.70	4.20	1.69	4 patins + 1 sgle	450 / 10
R 271 D	270	400	4.70	4.20	1.69	4 patins + 1 sgle	145 / 70 x 13
R 270 DCH	270	400	4.70	4.50	1.69	4 patins + 1 DCH	450 / 10
R 271 DCH	270	400	4.70	4.50	1.69	4 patins + 1 DCH	145 / 70 x 13



CATA mono



CATA double

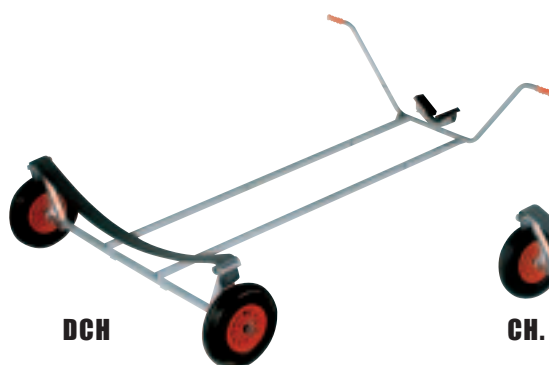

DCH



CH 3 DS



CH OPT.

	Suivant version Longueur bateau	P.T.C.	Suivant version Longueur remorque	Suivant version Largeur remorque	Roues
CH OPT	optimist	110	1.30	1.50	400 x 8 2 PR
CH 3 DS	laser-420-470	220	3.50	1.80	400 X 8 2 PR
DCH	420-470	220	2.00	1.80	400 X 8 2 PR
CATA mono	14 pieds	200	2.65	réglable	400 X 8 2 PR
CATA double	15-21 pieds	150-250	2.50	réglable	400 x 8 2 PR x (2) (4)

Photos non contractuelles



CATA double *



CATA simple *

	Variable suivant version			Suivant version		
	Charge utile	P.T.C.	Longueur bateau	Longueur remorque	Largeur remorque	Roues
R 150 CATA	200	320	12-14 pieds	4.80	1.69	450 / 10
R 151 CATA	200	320	12-14 pieds	4.80	1.69	145 / 70 x 13
R 300 CATA	300	450	15-16 pieds	4.80	1.69	450 / 10
R 301 CATA	300	450	15-16 pieds	4.80	1.69	145 / 70 x 13
R 350 CATA	350	499	17-18 pieds	5.50	1.69	450 / 10
R 351 CATA	350	499	17-18 pieds	5.50	1.69	145 / 70 x 13
R 501 CATA	450	650	18-21 pieds	6.50	1.69	155 / 70 x 13
R 551 CATA double	500	750	18-25 pieds	6.90	1.69	155 / 70 x 13

*option coffre



20 canoës

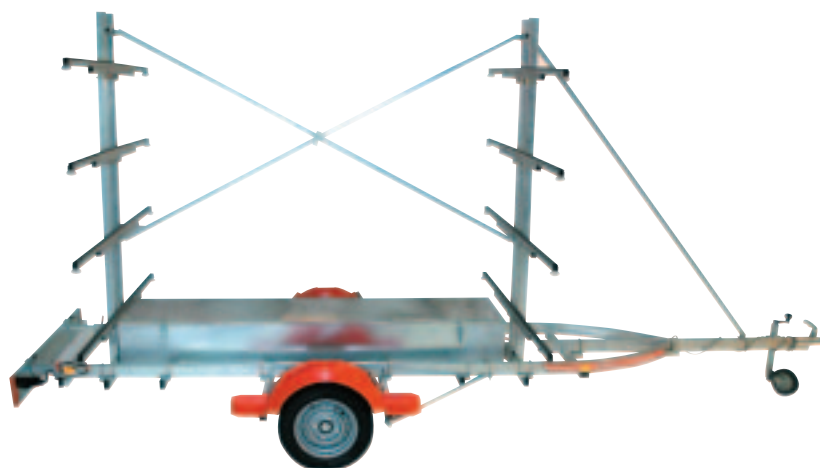

8 canoës (coffre en option)



10 canoës spécial

16 canoës





	Variable suivant version Charge utile	P.T.C.	Suivant version Longueur remorque	Suivant version Largeur remorque	Roues
R 330 OPTI 3-4	330	490	4.20	1.89	450 x 10
R 331 OPTI 3-4	330	490	4.20	1.89	145 / 70 x 13
R 401 OPTI 6	350	490	6.90	1.89	145 / 70 x 13
R 501 OPTI 6-8	450	650	6.90	1.89	145 / 70 x 13
R 501 F OPTI 6-8	450	650	6.90	1.89	145 / 70 x 13
R 401 D2	350	499	4.20	1.89	145 / 70 x 13
R 551 D3	450	750	5.00	1.89	155 / 70 x 13
R 551 F D3	450	750	5.00	1.89	155 / 70 x 13

Remorque Dériveur



Remorque Opt.

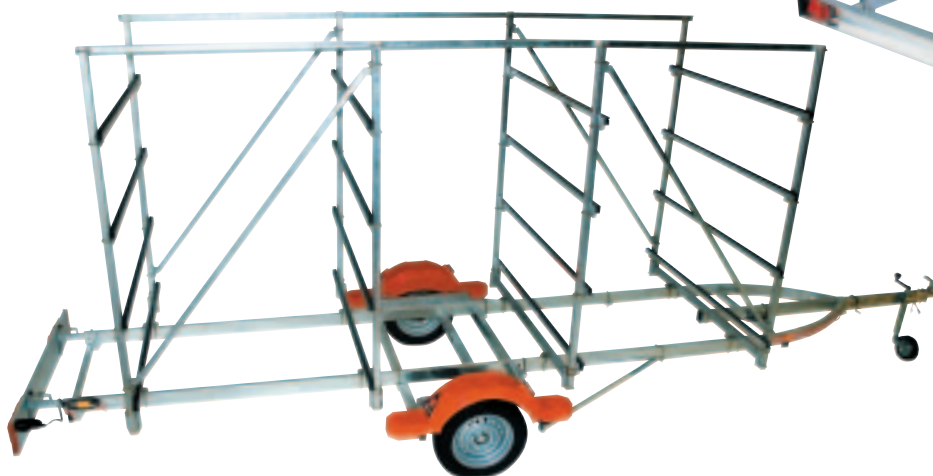

	Variable suivant version Charge utile	P.T.C.	Suivant version Longueur remorque	Suivant version Largeur remorque	Roues
R 210 4 P	210	320	4.00	1.69	450 / 10
R 211 4 P	210	320	4.00	1.69	145 / 70 x 13
R 270 6 P	270	400	4.20	1.69	450 / 10
R 271 6 P	270	400	4.20	1.69	145 / 70 x 13
R 330 8 P	350	499	5.00	1.89	450 / 10
R 331 8 P	350	499	5.00	1.89	145 / 70 x 13
R 270 4 C	270	400	4.00	1.69	450 / 10
R 271 4 C	270	400	4.00	1.69	145 / 70 x 13
R 330 6 C	350	499	4.20	1.89	450 / 10
R 331 6 C	350	499	4.20	1.89	145 / 70 x 13
R 501 8 C	450	650	5.50	1.89	155 / 70 x 13
R 501 F 8 C	450	650	5.50	1.89	155 / 70 x 13
R 551 10 C	500	750	5.50	1.89	155 / 70 x 13
R 551 F 10 C	500	750	5.50	1.89	155 / 70 x 13



VOILIER, DÉRIVEUR ET QUILLARD



REMRQUES



R 801 VF à R 2802 VF



R 651 VMF à R 2552 VMF



	Suivant version	Charge utile	P.T.C.	Longueur bateau	Suivant version	Longueur remorque	Largeur remorque	Roues
R 651	VMF	650	880	5.20	5.00	2.10	165 / 70 x 13	
R 701	VMF	700	1000	5.50	6.00	2.10	185 / 70 x 13	
R 801	VMF	800	1100	5.50	6.00	2.10	185 / 70 x 13	
R 851	VMF	850	1150	5.50	6.00	2.10	165 R 13 C	
R 901	VMF	900	1200	5.50	6.00	2.30	185 x 14 RC	
R 1001	VMF	1000	1300	5.50	6.00	2.30	185 x 14 RC	
R 1101	VMF	1100	1400	5.50	6.00	2.30	185 x 14 RC	
R 1181	VMF	1180	1500	5.50	6.00	2.30	185 x 14 RC	
R 1301	VMF	1300	1600	6.00	6.50	2.30	165 / 70 x 13	
R 1052	VMF	1000	1400	6.00	6.50	2.30	165 / 70 x 13	
R 1252	VMF	1200	1570	6.00	6.50	2.30	165 / 70 x 13	
R 1452	VMF	1400	1800	6.00	6.50	2.30	165 / 70 x 13	
R 1602	VMF	1600	2000	6.50	7.00	2.30	185 / 70 x 13	
R 1802	VMF	1800	2200	6.50	7.00	2.49	185 x 14 RC	
R 2052	VMF	2000	2500	7.00	7.50	2.49	185 x 14 RC	
R 2352	VMF	2250	2700	7.50	8.00	2.49	185 x 14 RC	
R 2552	VMF	2500	3100	8.00	8.50	2.49	185 x 14 RC	
R 801	VF	800	1100	6.00	5.50	2.10	185 / 70 x 13	
R 851	VF	850	1150	6.00	5.50	2.10	165 R 13 C	
R 901	VF	900	1200	6.00	5.50	2.30	185 x 14 RC	
R 1001	VF	1000	1300	6.00	5.50	2.30	185 x 14 RC	
R 1101	VF	1100	1400	6.00	5.50	2.30	185 x 14 RC	
R 1181	VF	1180	1500	6.50	6.00	2.30	185 x 14 RC	
R 1301	VF	1300	1600	6.50	6.00	2.30	185 x 14 RC	
R 1252	VF	1200	1570	7.00	6.50	2.30	165 / 70 x 13	
R 1452	VF	1400	1800	7.00	6.50	2.30	165 / 70 x 13	
R 1602	VF	1600	2000	7.00	6.50	2.30	185 / 70 x 13	
R 1802	VF	1800	2200	7.50	7.00	2.49	185 x 14 RC	
R 2052	VF	2000	2500	7.50	7.00	2.49	185 x 14 RC	
R 2352	VF	2250	2700	8.00	7.50	2.49	185 x 14 RC	
R 2552	VF	2500	3100	8.00	7.50	2.49	185 x 14 RC	
R 2802	VF	2800	3500	8.50	8.00	2.49	195 x 14 C	

Photos non contractuelles



R 301 JET *

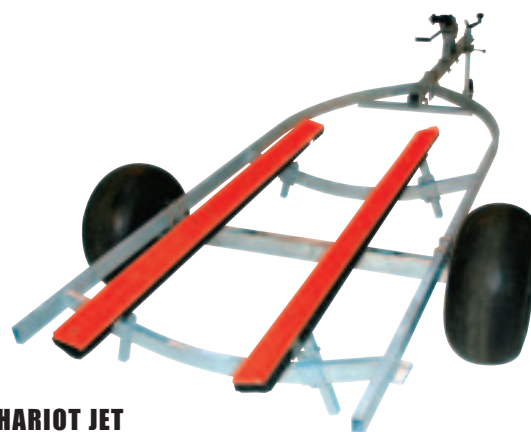

CHARIOT JET



R 501 JET **



Support treuil

	Suivant version Charge utile	P.T.C.	Longueur bateau	Suivant version Longueur remorque	Suivant version Largeur remorque	Roues
R 301 Jet simple	400	499	-	4.00	1.59	145 / 70 R 13
R 501 Jet	500	650	-	4.00	1.59	155 / 70 R 13
Chariot Jet	300	400	-	4.00	1.59	22 x 11 - 8/2 PR
R 551 Jet double	500	750	-	5.00	2.49	155 / 70 R 13
R 801 Jet double F	800	1100	-	5.50	2.49	185 / 70 R 13

*Essieu réglable ** Feux séparés en option



R 210 P
R 211 P

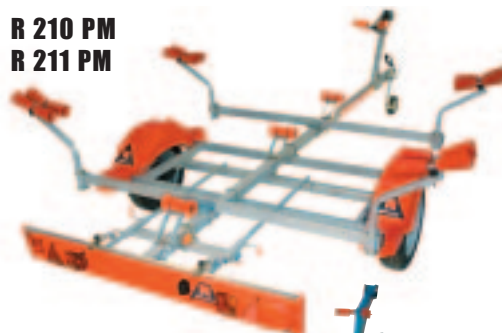

R 210 PM
R 211 PM

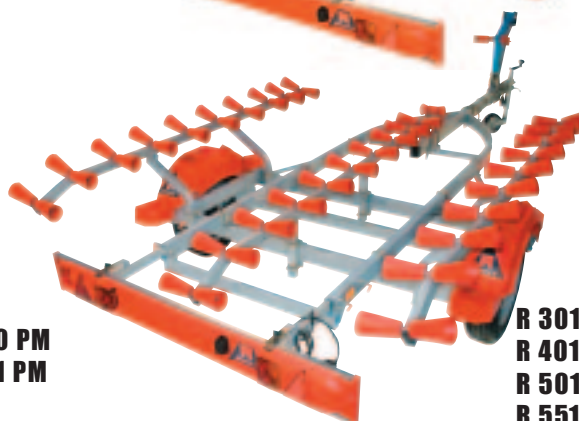

R 270 PM
R 271 PM

R 301 PM - R 351 PM
R 401 PM
R 501 PM - R 501 PMF
R 551 PM - R 551 PMF

	Variable suivant version		Suivant version			Hauteur	Nombre roueaux	Roues
	Charge utile	P.T.C.	Longueur bateau	Longueur remorque	Largeur remorque			
R 210 P	210	320	3.50	4.00	1.69	0.55	6 patins	450 / 10
R 211 P	210	320	3.50	4.00	1.69	0.55	6 patins	145 / 70 x 13
R 210 PM	210	320	3.50	4.00	1.69	0.55	25	450 / 10
R 211 PM	210	320	3.50	4.00	1.69	0.55	25	145 / 70 x 13
R 270 PM	240	350	4.40	4.00	1.89	0.60	45	450 / 10
R 271 PM	240	350	4.40	4.00	1.89	0.60	45	145 / 70 x 13
R 300 PM	300	450	4.40	4.20	1.89	0.60	51	450 / 10
R 301 PM	300	450	4.40	4.20	1.89	0.60	51	145 / 70 x 13
R 350 PM	350	470	4.70	4.70	1.89	0.60	51	450 / 10
R 351 PM	350	470	4.70	4.70	1.89	0.60	51	145 / 70 x 13
R 401 PM	380	499	4.70	4.70	1.89	0.60	51	145 / 70 x 13
R 501 PM	500	650	5.50	5.00	1.89	0.63	63	155 / 70 x 13
R 501 PMF	500	650	5.50	5.00	1.89	0.63	63	155 / 70 x 13
R 551 PM	550	750	5.50	5.00	1.89	0.63	63	155 / 70 x 13
R 551 PMF	550	750	5.50	5.00	1.89	0.63	63	155 / 70 x 13

*option roue de secours

Photos non contractuelles



R 350 PMSR - R 351 PMSR
R 501 PMSR - R 501 PMFSR
R 551 PMSR - R 551 PMFSR
R 651 PMFSR - R 801 PMFSR

	Variable suivant version			Suivant version				
	Charge utile	P.T.C.	Longueur bateau	Longueur remorque	Largeur remorque	Hauteur	Nombre rouleaux	Roues
R 350 PMSR	350	499	4.50	4.70	1.89	0.55	51	450 / 10
R 351 PMSR	350	499	4.50	4.70	1.89	0.55	51	145 / 70 x 13
R 501 PMSR	500	650	5.50	5.00	1.89	0.57	55	155 / 70 x 13
R 501 PMFSR	500	650	5.50	5.50	1.89	0.57	55	155 / 70 x 13
R 551 PMSR	550	750	5.50	5.50	1.89	0.57	55	155 / 70 x 13
R 551 PMFSR	550	750	5.50	5.50	1.89	0.57	55	155 / 70 x 13
R 651 PMFSR	650	880	5.50	5.50	2.10	0.57	67	165 / 70 x 13
R 801 PMFSR	800	1100	6.00	6.00	2.10	0.57	67	185 / 70 x 13

*option roue de secours



R 210 M - R 211 M

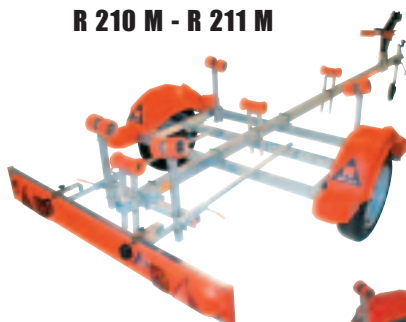

R 270 M - R 271 M

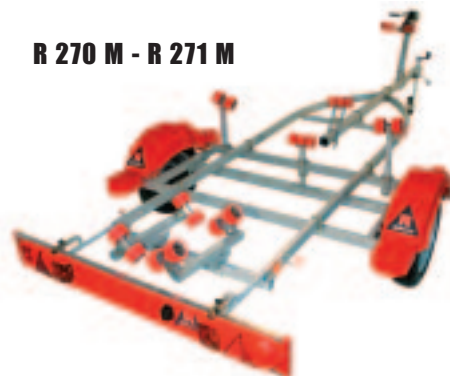

R 330 M - R 331 M



R 501 M - R 501 MF
R 550 M - R 551 MF

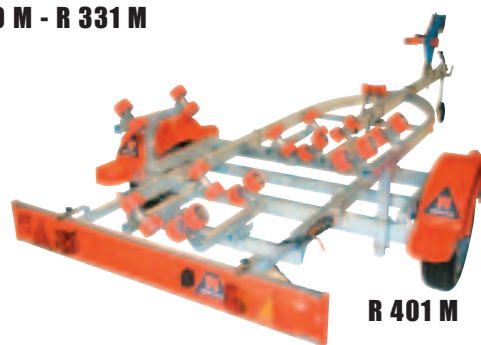

R 401 M

	Variable suivant version		Longueur bateau	Suivant version		Hauteur	Nombre rouleaux	Roues
	Charge utile	P.T.C.		Longueur remorque	Largeur remorque			
R 210 M	240	350	3.70	4.00	1.69	0.42	17	450 / 10
R 211 M	240	350	3.70	4.00	1.69	0.42	17	145 / 70 x 13
R 270 M	320	400	4.00	4.20	1.69	0.42	18	450 / 10
R 271 M	320	400	4.00	4.20	1.69	0.42	18	145 / 70 x 13
R 330 M	350	470	4.40	4.50	1.89	0.44	22	450 / 10
R 331 M	350	470	4.40	4.50	1.89	0.44	22	145 / 70 x 13
R 401 M	390	499	4.70	5.00	1.89	0.44	27	145 / 70 x 13
R 501 M	500	650	4.70	5.00	1.89	0.44	27	155 / 70 x 13
R 501 MF	500	650	4.70	5.20	1.89	0.44	27	155 / 70 x 13
R 551 M	550	750	4.70	5.00	1.89	0.44	27	155 / 70 x 13
R 551 MF	550	750	4.70	5.20	1.89	0.44	27	155 / 70 x 13

Photos non contractuelles



R 651 MF à R 1301 MF

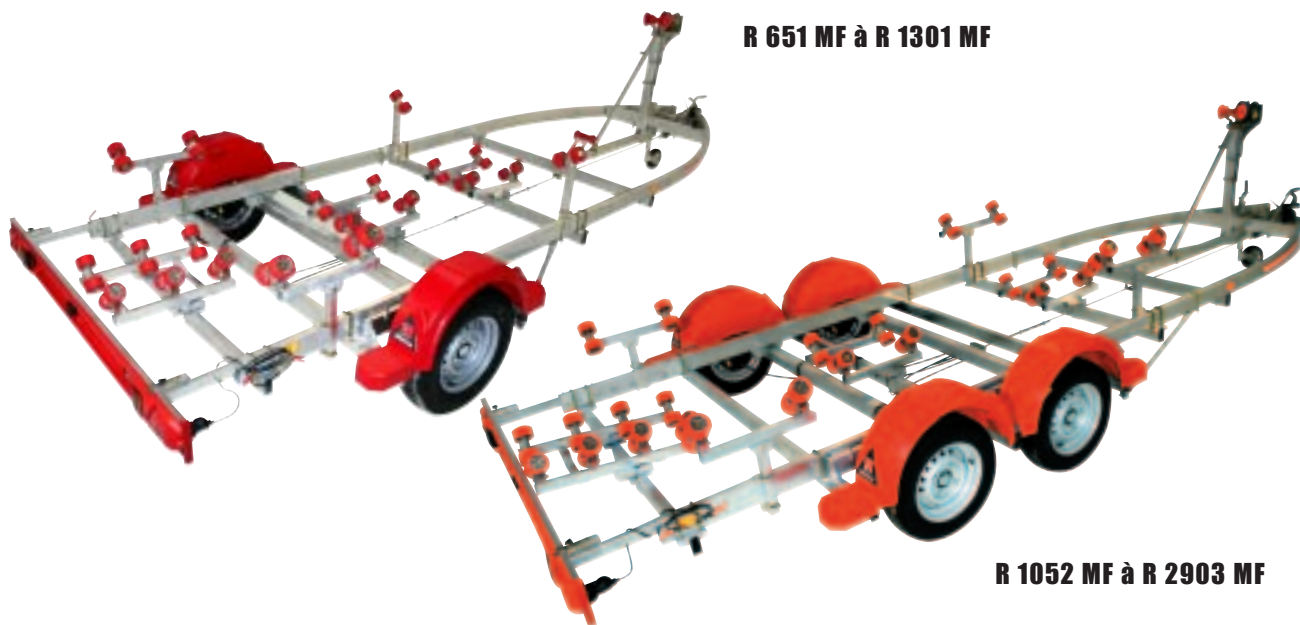

R 1052 MF à R 2903 MF

	Variable suivant version		Suivant version			Hauteur	Nombre rouleaux	Roues
	Charge utile	P.T.C.	Longueur bateau	Longueur remorque	Largeur remorque			
R 651 MF	650	880	5.20	5.50	2.10	0.48	43	165 / 70 x 13
R 701 MF	700	1000	5.50	6.00	2.10	0.48	43	185 / 70 x 13
R 801 MF	800	1100	5.50	6.00	2.10	0.48	43	185 / 70 x 13
R 851 MF	850	1150	5.50	6.00	2.10	0.52	43	165 R13 C
R 901 MF	900	1200	5.50	6.00	2.30	0.52	43	185 x 14 RC
R 1001 MF	1000	1300	5.50	6.00	2.30	0.52	43	185 x 14 RC
R 1101 MF	1100	1400	5.50	6.00	2.30	0.52	43	185 x 14 RC
R 1181 MF	1180	1500	6.00	6.50	2.30	0.52	43	185 x 14 RC
R 1301 MF	1300	1600	6.00	6.50	2.30	0.52	43	185 x 14 RC
R 1052 MF	1000	1400	5.50	6.00	2.30	0.48	51	165 / 70 x 13
R 1252 MF	1200	1570	5.50	6.00	2.30	0.49	51	165 / 70 x 13
R 1452 MF	1400	1800	5.50	6.00	2.30	0.49	51	165 / 70 x 13
R 1602 MF	1600	2000	6.50	7.00	2.30	0.50	51	185 / 70 x 13
R 1802 MF	1800	2200	6.50	7.00	2.49	0.53	51	185 x 14 RC
R 2052 MF	2000	2500	7.00	7.50	2.49	0.52	59	185 x 14 RC
R 2352 MF	2250	2700	7.50	8.00	2.49	0.52	59	185 x 14 RC
R 2552 MF	2500	3100	8.00	8.50	2.49	0.53	67	185 x 14 RC
R 2802 MF	2800	3500	8.70	9.20	2.49	0.53	67	195 x 14 RC
R 2903 MF	2900	3500	8.70	9.20	2.49	0.53	67	185 x 14 RC

Longueur spéciale : nous consulter



BATEAU PÊCHE, PROMENADE À QUILLE —



REMORQUES



R 651 CMF - R 701 CMF - R 801 CMF
R 851 CMF - R 901 CMF
R 1001 CMF - R 1101 CMF
R 1301 CMF



R 401 CM
R 501 CM - R 501 CMF
R 551 CM - R 551 CMF

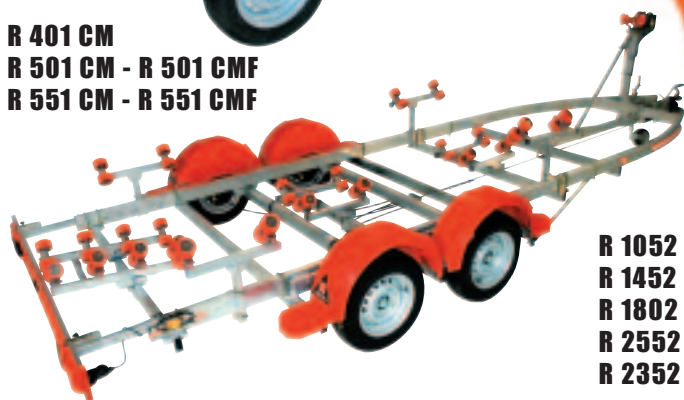

R 1052 CMF - R 1252 CMF
R 1452 CMF - R 1602 CMF
R 1802 CMF - R 2052 CMF
R 2552 CMF - R 2802 CMF
R 2352 CMF - R 2903 CMF



	Variable suivant version		Suivant version				Hauteur	Nombre roulements	Roues
	Charge utile	P.T.C.	Longueur bateau	Longueur remorque*	Largeur remorque				
R 401 CM	390	499	4.70	5.00	1.89	0.44	23	145 / 70 x 13	
R 501 CM	500	650	4.70	5.00	1.89	0.44	23	155 / 70 x 13	
R 501 CMF	500	650	4.70	5.20	1.89	0.44	23	155 / 70 x 13	
R 551 CM	550	750	4.70	5.00	1.89	0.44	23	155 / 70 x 13	
R 551 CMF	550	750	4.70	5.20	1.89	0.44	23	155 / 70 x 13	
R 651 CMF	650	880	5.00	5.50	2.10	0.48	34	165 / 70 x 13	
R 701 CMF	700	1000	5.50	6.00	2.10	0.48	34	185 / 70 x 13	
R 801 CMF	800	1100	5.50	6.00	2.10	0.48	34	185 / 70 x 13	
R 851 CMF	850	1150	5.50	6.00	2.10	0.52	34	165 R 13 C	
R 901 CMF	900	1200	5.50	6.00	2.30	0.52	34	185 x 14 RC	
R 1001 CMF	1000	1300	5.50	6.00	2.30	0.52	34	185 x 14 RC	
R 1101 CMF	1100	1450	5.50	6.00	2.30	0.52	34	185 x 14 RC	
R 1181 CMF	1180	1500	6.00	6.50	2.30	0.52	34	185 x 14 RC	
R 1301 CMF	1300	1600	6.00	6.50	2.30	0.52	34	185 x 14 RC	
R 1052 CMF	1000	1400	6.00	6.50	2.30	0.48	42	165 / 70 x 13	
R 1252 CMF	1200	1570	6.00	6.50	2.30	0.49	42	165 / 70 x 13	
R 1452 CMF	1400	1800	6.00	6.50	2.30	0.49	42	165 / 70 x 13	
R 1602 CMF	1600	2000	6.00	6.50	2.30	0.50	42	185 / 70 x 13	
R 1802 CMF	1800	2200	6.50	7.00	2.49	0.52	42	185 x 14 RC	
R 2052 CMF	2000	2500	7.00	7.50	2.49	0.52	42	185 x 14 RC	
R 2352 CMF	2250	2700	7.50	8.00	2.49	0.53	42	185 x 14 RC	
R 2552 CMF	2500	3100	8.00	8.50	2.49	0.53	44	185 x 14 RC	
R 2802 CMF	2800	3500	8.00	8.50	2.49	0.53	44	195 R 14 C	

Longueur spéciale : nous consulter

Photos non contractuelles



Chariot CH 100

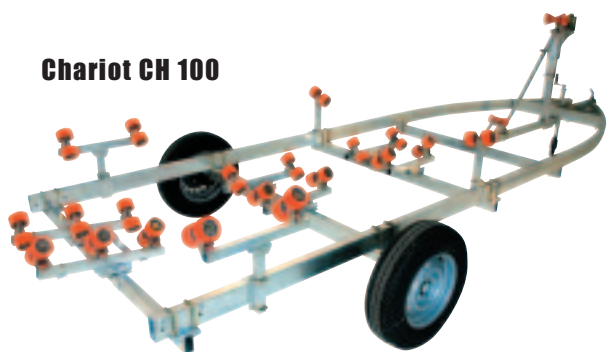

Chariot CH 50

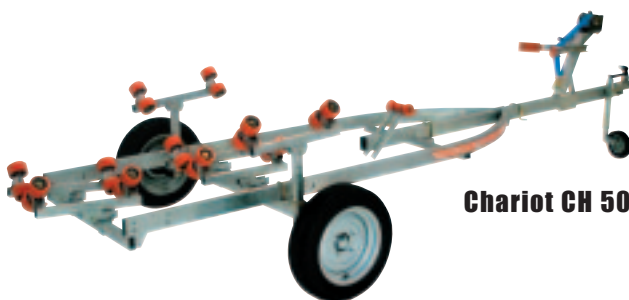

Ber quatre roues
moteur

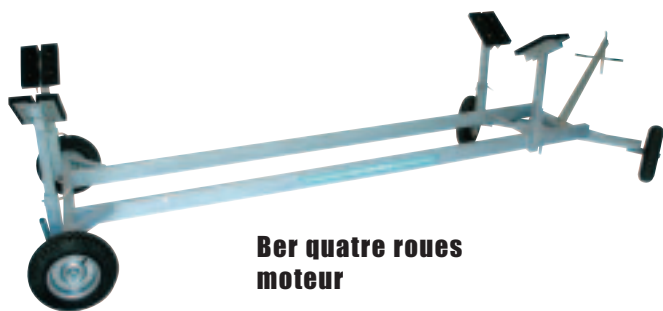

Ber quatre roues
voilier

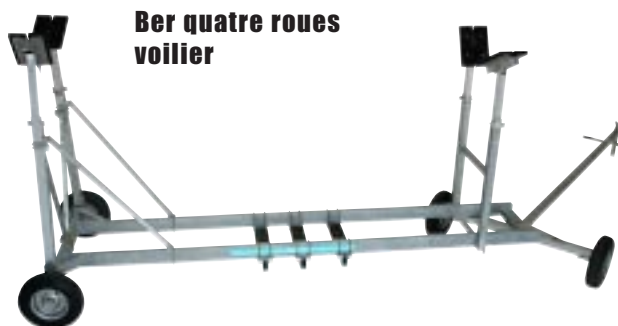

	Suivant version Charge utile	Moyeux étanches	Longueur bateau	Longueur remorque	Suivant version Largeur remorque	Roues
CH 20	150		4.00	4.00	1.70	480 x 8
CH 40	400	oui	4.00	4.30	1.90	450 x 10
CH 50	500	oui	5.00	4.50	1.90	145 x 13
CH 70	700	oui	5.50	5.50	2.10	165 / 70 x 13
CH 100	1000	oui	6.00	6.00	2.30	185 x 14
CH 130	1300	oui	6.00	6.00	2.30	185 x 14
CH 180	1800	oui	7.00	7.00	2.50	185 x 14 (4)
CH 250	2500	oui	8.00	8.00	2.50	185 x 14 (4)
BER 1000	1000		5 / 5.50			400 x 6 PR
BER 1500	1500		6 / 6.50			400 x 6 PR
BER 2000	2000		7.00			400 x 6 PR
BER 3000	3000		8.00			400 x 6 PR



REMORQUE SPECIALE BATEAU DE SKI



REMORQUE SPECIALE CATAMARAN

REMORQUES CARÈNES À STEPS : NOUS CONSULTER



**REMORQUE SPECIALE FIRST 210
MISE À L'EAU - ROUTE**

REMORQUE PORTE VOITURE

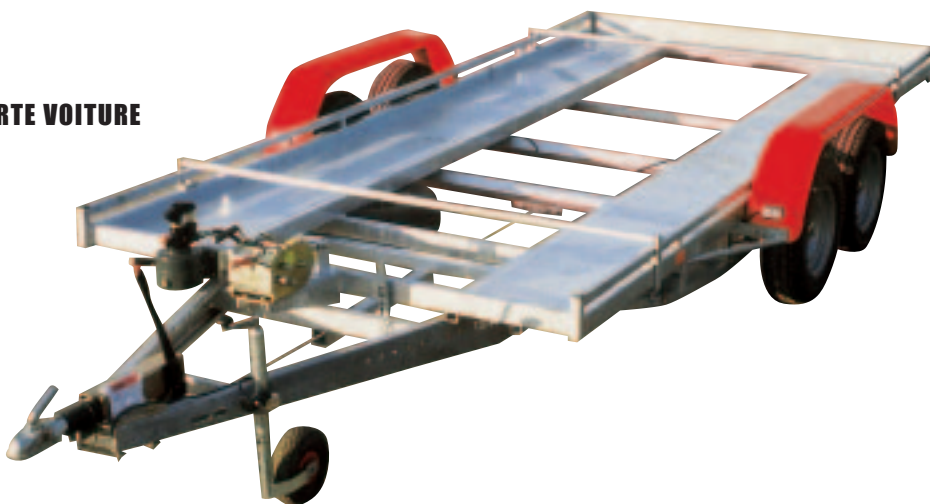

REMORQUE SPECIALE VOILIER



Autres productions

REMORQUES : Bennes hydrauliques
Portes voitures
Portes Motos
Espace vert
Bagagères

Devis gratuit
sur demande



Siège social S.A.I.N.

Rue Edouard Branly
ZI Nord est
14100 HERMIVAL LES VAUX

USINE OUEST CRAON

8, rue Denis Papin
53400 CRAON
Tél. 02 43 06 13 42
Fax 02 43 06 01 36
Internet : www.remorques-rocca.com

USINE EST BESANÇON ZI

Roche Lez Beauprés
25220 ROCHES LEZ BEAUPRES
Tél. 06 08 18 91 59
Fax 03 81 55 43 48

Succursales LA ROCHELLE

Mobile 06 85 52 61 70

MARTIGUES

8, avenue de Lascos
ZI Sud Port à Sec
13500 MARTIGUES
Tél. 04 42 07 34 75
Fax 04 42 40 39 59
Mobile 06 14 49 82 56

Revendeurs ESPAGNE

TERMINUR IBERICA
C/16 DE JULIO
NAVE SERMAN 91/95
07009 PALMA DE MALLORCA
Tél. 00 34 971 75 90 95
Fax 00 34 971 43 26 92

BELGIQUE

AUTO NAUTIQUE
rue G. Lemans 65-67
B 4432 ALLEUR
Tél. 00 32 42 46 07 18
Fax 00 32 42 46 55 20

SUISSE

Ets THIEL
14 route des Falaises
2000 NEUCHÂTEL
Tél. 00 41 32 725 75 00
Fax 00 41 32 724 69 40